

ext. 80 bar

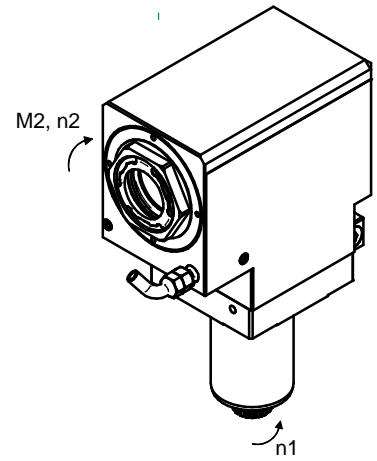
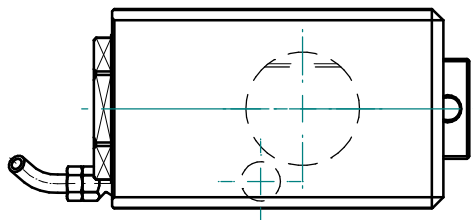
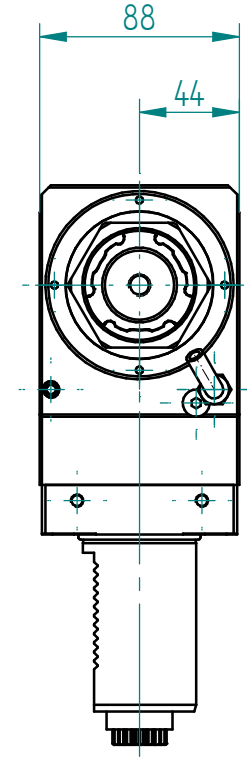
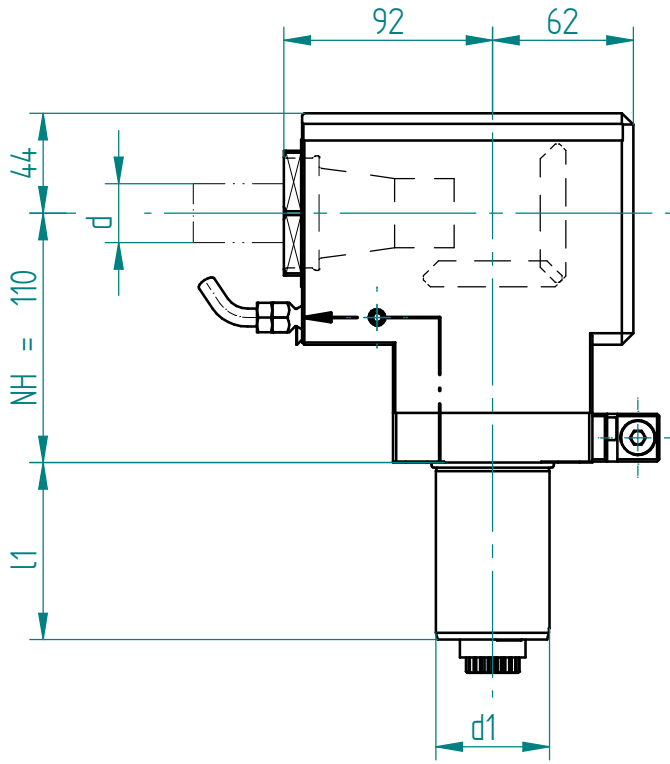

Änderungen vorbehalten. Subject to modification

Schaft shank		Drehmoment torque	Drehzahl tool speed	Leistung output	Übersetzung gear ratio	Wkzg.Aufnahme Spannbereich tool holding fixture clamping range	Kupplung coupling	Ausführung version	Bestell-Nr. order N°
DIN 69880									
d1 mm	l1 mm	M2 max Nm	n2 max 1/min	P max KW	i = n1: n2	Spannbereich d chucking capacity d			
50	78	100.0	4000	12.0	-1.00	DIN 6499 - 40 - I 3-26	DIN 5480 W 24x1.25x30x18	links left	106613

Erforderliche(r) Schlüssel zur Werkzeugspannung / necessary key(s) for tool clamping 106113

Rev 12/08 // Erst.:tba , erstellt am 2012.08.16 // Prüf.:has, geprüft am 2012.08.21