

ext. 80 bar

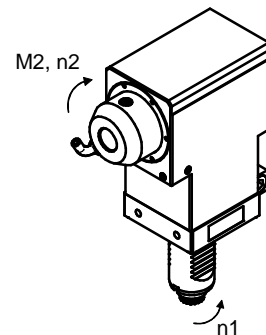
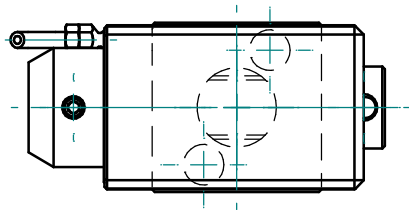
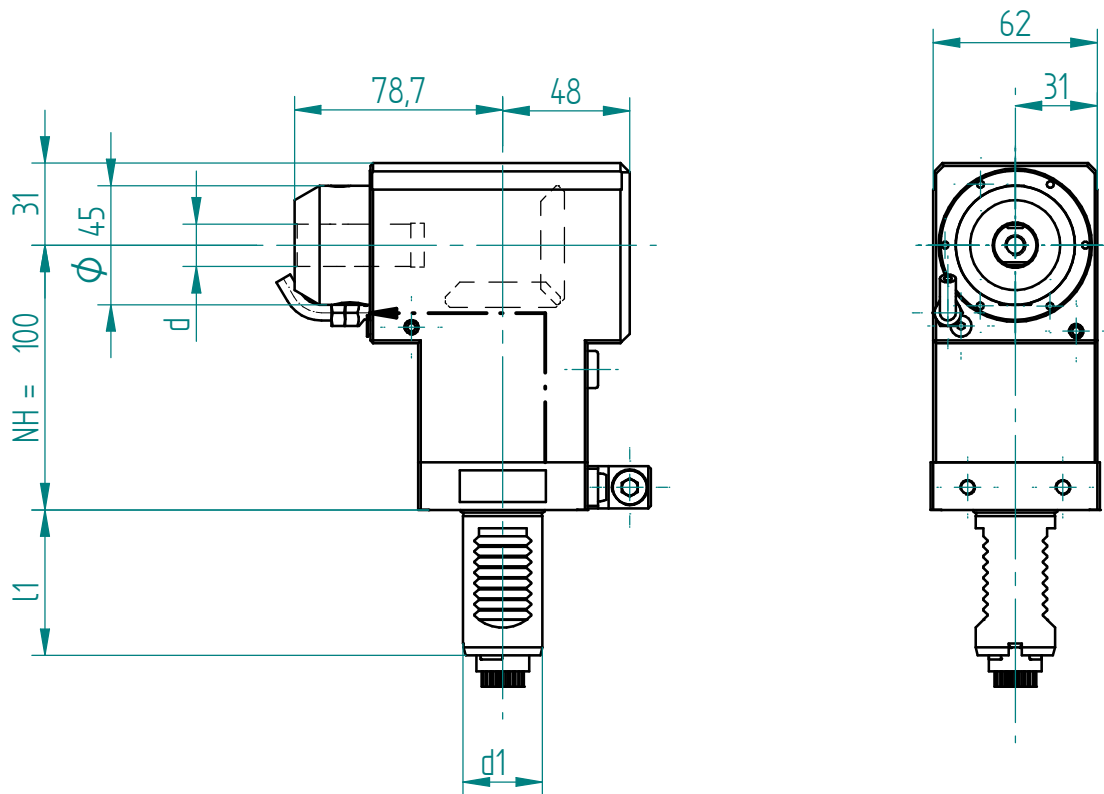

Änderungen vorbehalten. Subject to modification

Schaft shank		Drehmoment torque	Drehzahl tool speed	Leistung output	Übersetzung gear ratio	Wkzg.Aufnahme Spannbereich tool holding fixture clamping range	Kupplung coupling	Ausführung version	Bestell-Nr. order N°
DIN 69880									
d1 mm	l1 mm	M2 max Nm	n2 max 1/min	P max KW	i = n1: n2	Spannbereich d chucking capacity d			
30	55	32.0	7000	8.0	-1.00	DIN 1835 - B 16 16	DIN 5480 W 16x0.8 x30x18	universal universal	<b>113193</b>

Erforderliche(r) Schlüssel zur Werkzeugspannung / necessary key(s) for tool clamping

Inbusschlüssel / Allen head wrench