

Typenblatt  
Data Sheet

Werkzeughalteraufnahme  
Werkzeugaufnahme mit Klemmung  
tool holding fixture ; tool location with clamping

  
**SAUTER**  
Mit uns dreht die Welt!

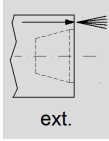
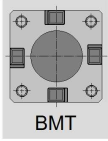

int. bar  
ext. 80 bar

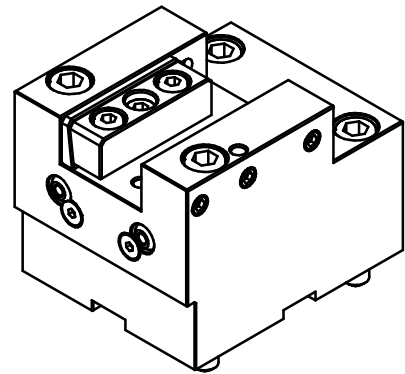
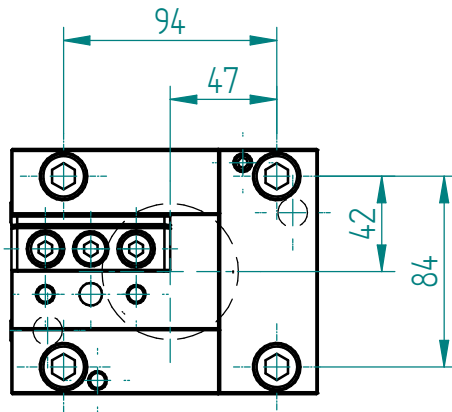
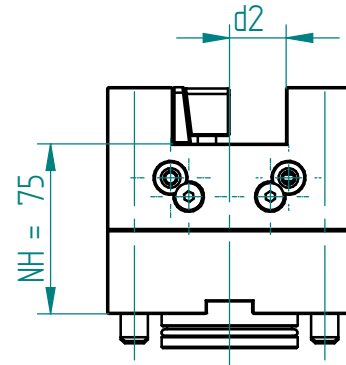
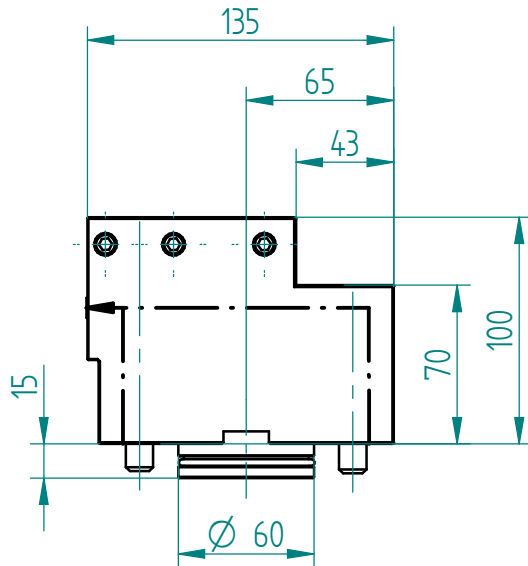

Rev 12/2014 // Erst.:fre , erstellt am 2016.06.29 // Prüf.:has , geprüft am 2016.06.29

Änderungen vorbehalten. Subject to modification

Schnittstelle Revolver interface tool turret	Werkzeugaufnahme tool location	Ausführung version	Bestell-Nr. order N°
BMT Mori Seiki 60	Aufnahme d2 location d2 Werkzeughalter mit Vierkantaufnahme-25	universal universal	156340

Erforderliche(r) Schlüssel zur Werkzeugspannung / necessary key(s) for tool clamping

Inbusschlüssel / Allen head wrench