

ext. 80 bar

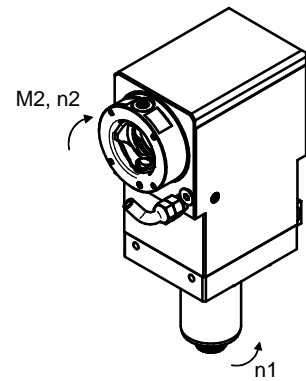
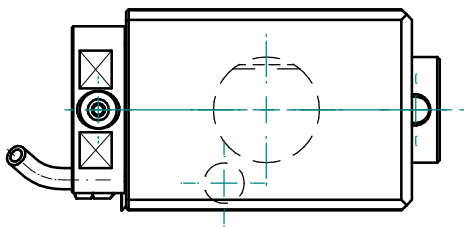
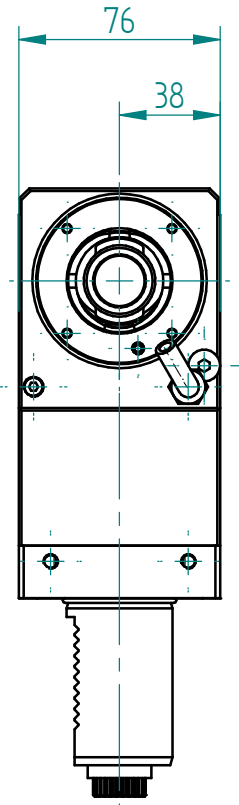
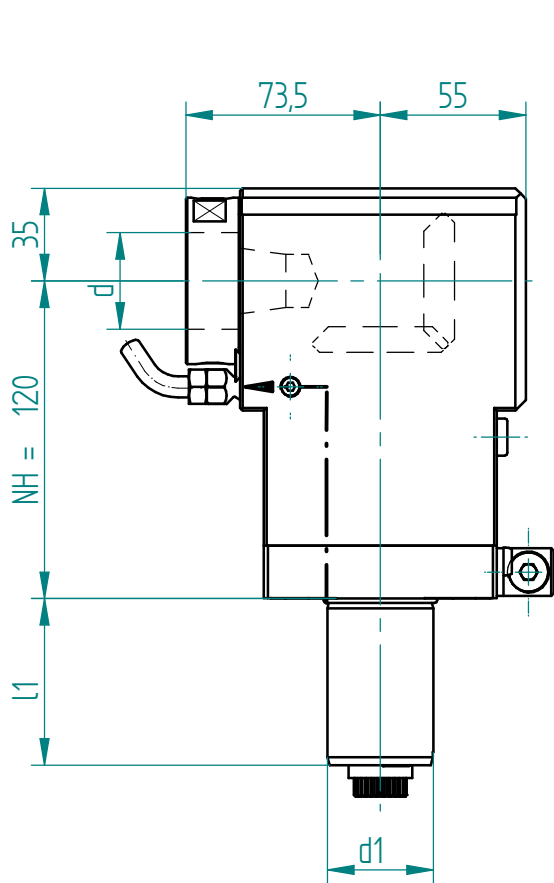

Änderungen vorbehalten. Subject to modification

Schaft shank		Drehmoment torque	Drehzahl tool speed	Leistung output	Übersetzung gear ratio	Wkzg.Aufnahme Spannbereich tool holding fixture clamping range	Kupplung coupling	Ausführung version	Bestell-Nr. order N°
DIN 69880									
d1 mm	l1 mm	M2 max Nm	n2 max 1/min	P max KW	i = n1: n2	Spannbereich d chucking capacity d			
40	63	63.0	6000	10.0	-1.00	Solidfix S4	DIN 5480 W 20x0.8 x30x24	links left	140892

Erforderliche(r) Schlüssel zur Werkzeugspannung / necessary key(s) for tool clamping

Inbusschlüssel / Allen head wrench