

ext. 80 bar

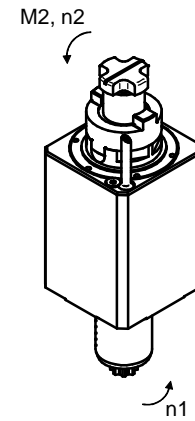
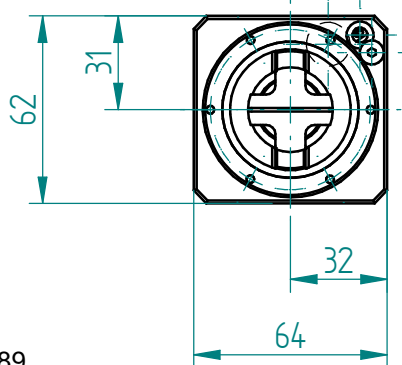
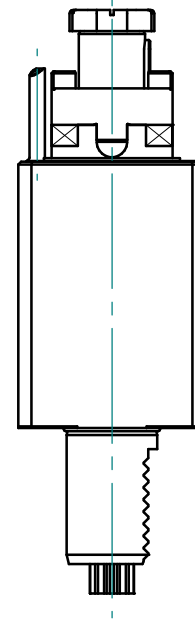
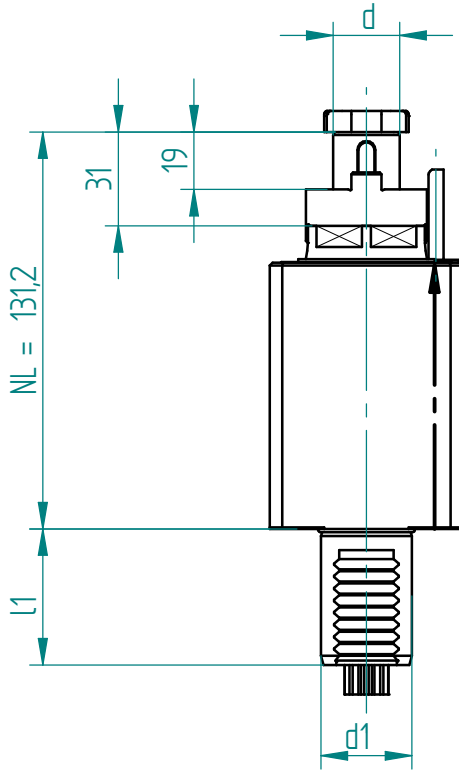

*nicht nach ISO 10889
*not according to ISO 10889

Änderungen vorbehalten. Subject to modification

Schnittstelle Revolver <i>interface tool turret</i>		Kupplung <i>coupling</i>	Drehmoment <i>torque</i>	Drehzahl <i>tool speed</i>	Leistung <i>output</i>	Übersetzung <i>gear ratio</i>	Wkzg.Aufnahme Spannbereich <i>tool holding fixture clamping range</i>	Ausführung <i>version</i>	Bestell-Nr. <i>order N°</i>
Schaft <i>shank</i>	ISO 10889								
d1 mm	l1* mm		M2 max Nm	n2 max 1/min	P max KW	i = n1: n2	Spannbereich d <i>chucking capacity d</i>		
30	45	DIN 5482 B 15x12	32.0	7000	8.0	1.00	DIN 6358 - 22 22	neutral <i>neutral</i>	104511

Erforderliche(r) Schlüssel zur Werkzeugspannung / *necessary key(s) for tool clamping*

103294