

int. 5-80 bar
ext. 80 bar
- \diamond 50 μ m
- Dry run: 100%

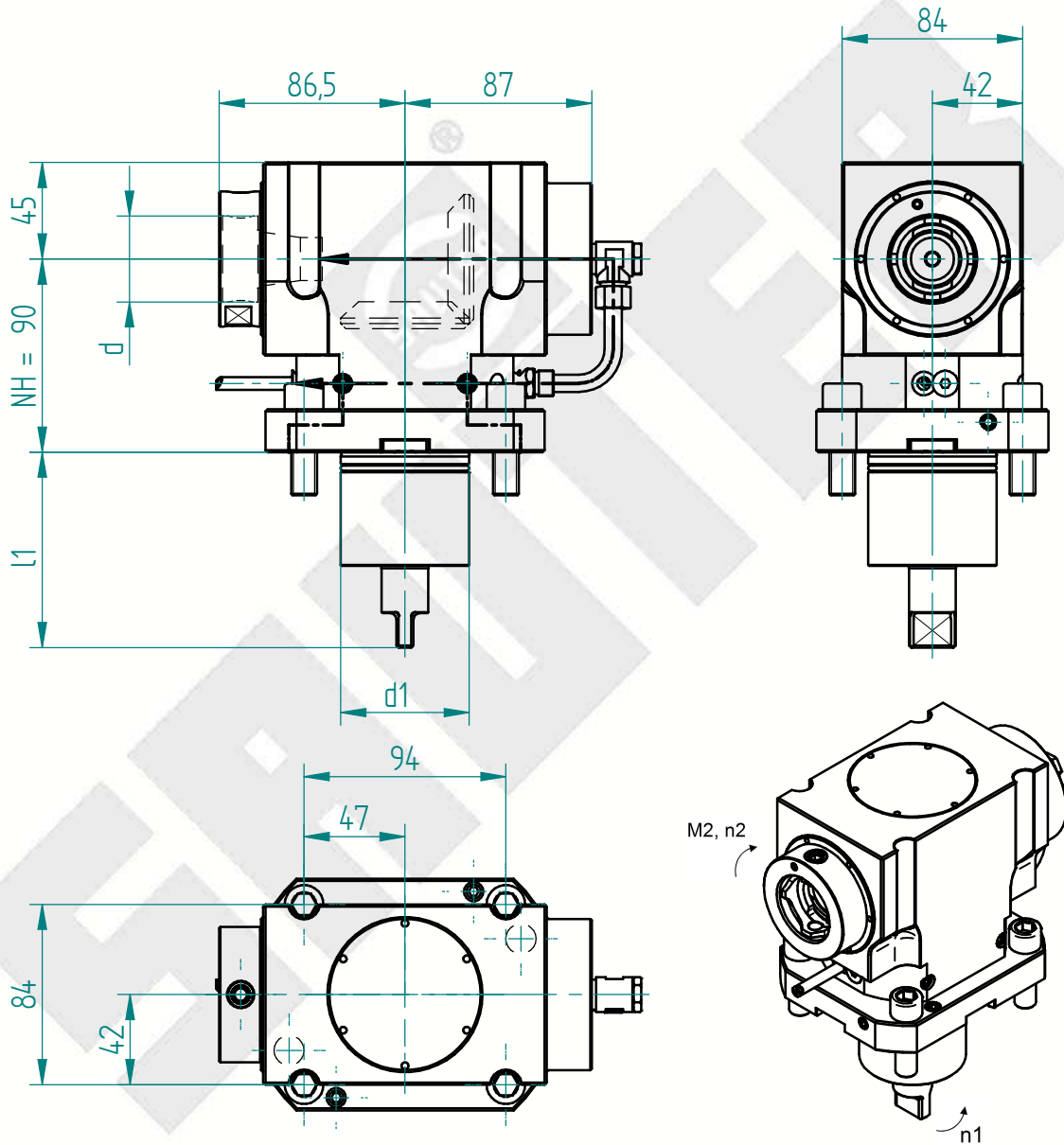

Schnittstelle Revolver interface tool turret		Drehmoment torque	Drehzahl tool speed	Leistung output	Übersetzung gear ratio	Wkzg.Aufnahme Spannbereich tool holding fixture clamping range	Ausführung version	Bestell-Nr. order N°	
Schaft / BG shank / size	Kupplung coupling								
d1 mm	l1 mm	M2 max Nm	n2 max 1/min	P max KW	i = n1: n2	Spannbereich d chucking capacity d			
60	91.0	BMT Mori Seiki 60	100.0	10000	5.5	1.000	Solidfix S4	universal universal	167821

Erforderliche(r) Schlüssel zur Werkzeugspannung / necessary key(s) for tool clamping
(nicht im Lieferumfang enthalten / not included in delivery)

Inbusschlüssel / Allen head wrench

