

Uchwyty do gwintowania z kompensacją osiową

Quick-change tapping chucks HSK, with length compensation

Gewindeschneid-Schnellwechselfutter HSK, mit Längenausgleich auf Zug und Druck

Резьбонарезные патроны с осевой компенсацией



AXIAL COMPENSATION

TAPPING

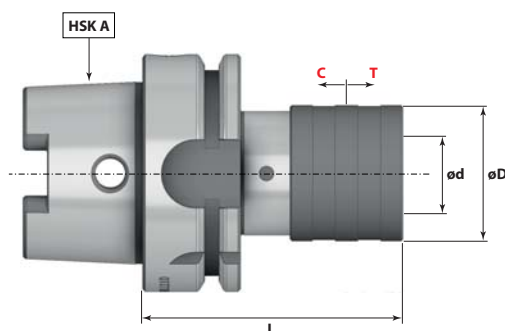

DIN 69893 (HSK A/C)

Kod produktu Order No. / Bestell-Nr. / Код товара	Stożek Holder (HSK)	ø d (Morse) (mm)	ø D (mm)	Zakres gwintowania Threading range (Thread)	L (mm)	T (mm)	C (mm)
HSK50A.GW19K.L72	50	19	48	M2 ÷ M14	72	7,5	7,5
HSK50A.GW31K.L110	50	31	60	M5 ÷ M24	110	12,5	12,5
HSK63A.GW19K.L72	63	19	38	M2 ÷ M14	72	7,5	7,5
HSK63A.GW31K.L110	63	31	54	M5 ÷ M24	110	12,5	12,5
HSK100A.GW19K.L80	100	19	36	M3 ÷ M14	80	7,5	7,5
HSK100A.GW31K.L100	100	31	53	M5 ÷ M24	100	12,5	12,5

Produkty powiązane / Related Products



Trzpienie z uchwytem wiertarskim monolityczne, prawe i lewe obroty

NC - Drill chucks for left and right rotation

NC - Bohrfutter für Rechts- und Linkslauf

Оправки со сверлильным патроном монолитные, правые и левые обороты

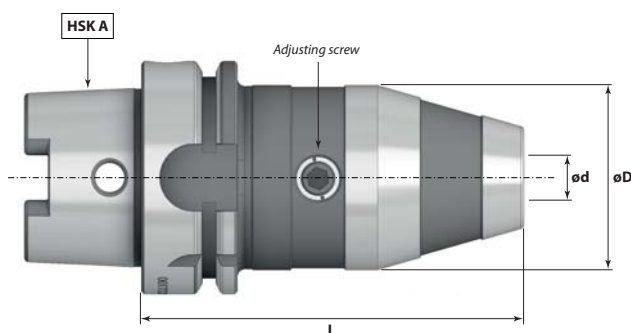

DIN 69893 (HSK A/C)

Kod produktu Order No. / Bestell-Nr. / Код товара	Stożek Holder (HSK)	Zakres mocowania Clamping range (mm)	ø D (mm)	L (mm)
HSK50A.UWK13.L111	50	1 ÷ 13	13	111
HSK50A.UWK16.L111	50	3 ÷ 16	16	111
HSK63A.UWK13.L111	63	1 ÷ 13	50	111
HSK63A.UWK16.L111	63	3 ÷ 16	57	111
HSK100A.UWK13.L111	100	1 ÷ 10	50	111
HSK100A.UWK16.L111	100	3 ÷ 16	57	111

G6,3
15 000 r.p.m.
STANDARD

Produkty powiązane / Related Products



Uchwyty narzędziowe wymienione w tabeli są standardem. Wykonujemy również uchwyty w wersji specjalnej wg ustaleń Klienta.
Toolholders in the table are the standard. We also make toolholders in the special version according to the customer settlements.