

ext. 70 bar

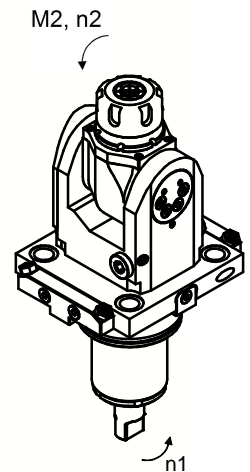
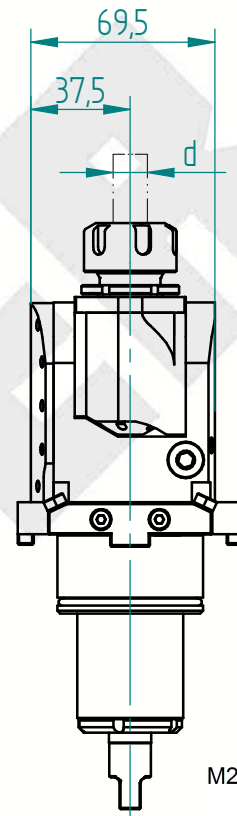
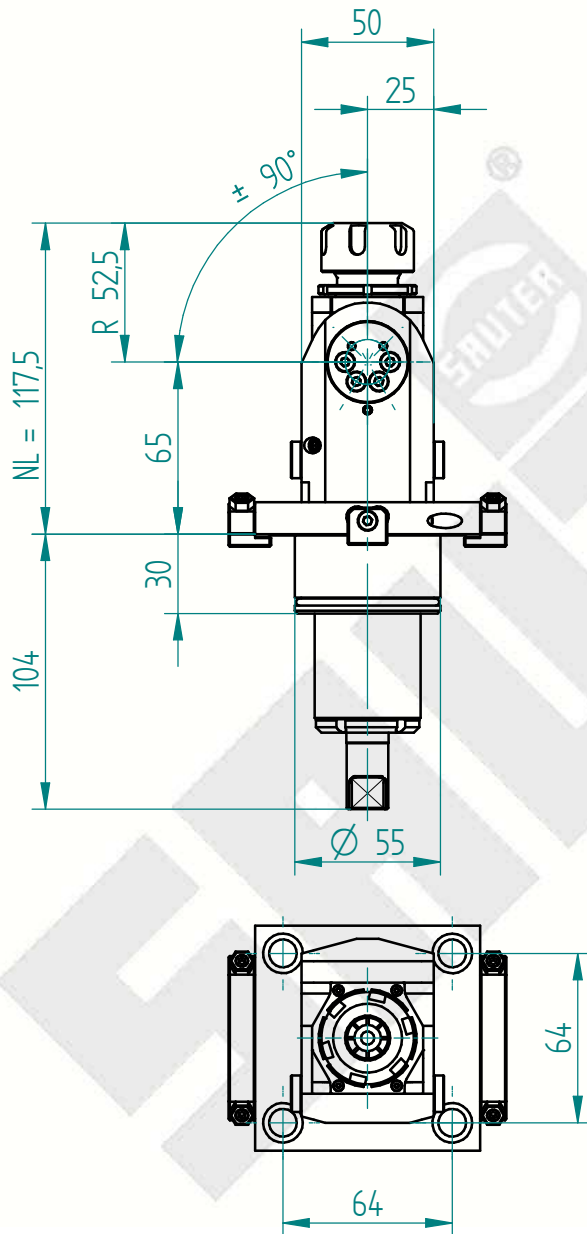

Änderungen vorbehalten. Subject to modification

Schnittstelle Revolver <i>interface tool turret</i>		Kupplung <i>coupling</i>	Drehmoment <i>torque</i>	Drehzahl <i>tool speed</i>	Leistung <i>output</i>	Übersetzung <i>gear ratio</i>	Wkzg.Aufnahme Spannbereich <i>tool holding fixture clamping range</i>	Ausführung <i>version</i>	Bestell-Nr. <i>order N°</i>
Schaft / BG <i>shank / size</i>									
d1 mm	l1 mm		M2 max Nm	n2 max 1/min	P max KW	i = n1 : n2	Spannbereich d <i>chucking capacity d</i>		
55	104.0	BMT BMT 55	15.0	8000	3.0	1.000	ISO 15488 - 20 - A 1-13	universal universal	172016

Rev 01/2019 // Erst.: has , erstellt am 2020.11.12 // Prüf.: , geprüft am

