

int. 80 bar  
ext. 80 bar  
-  $\diamond$  50 $\mu$ m  
- Dry run: max. 10%

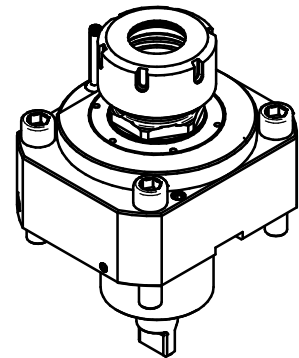
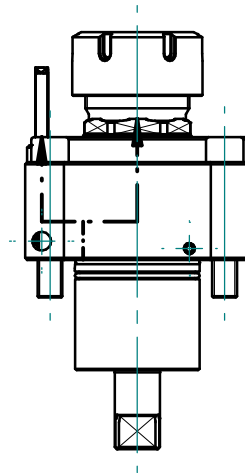
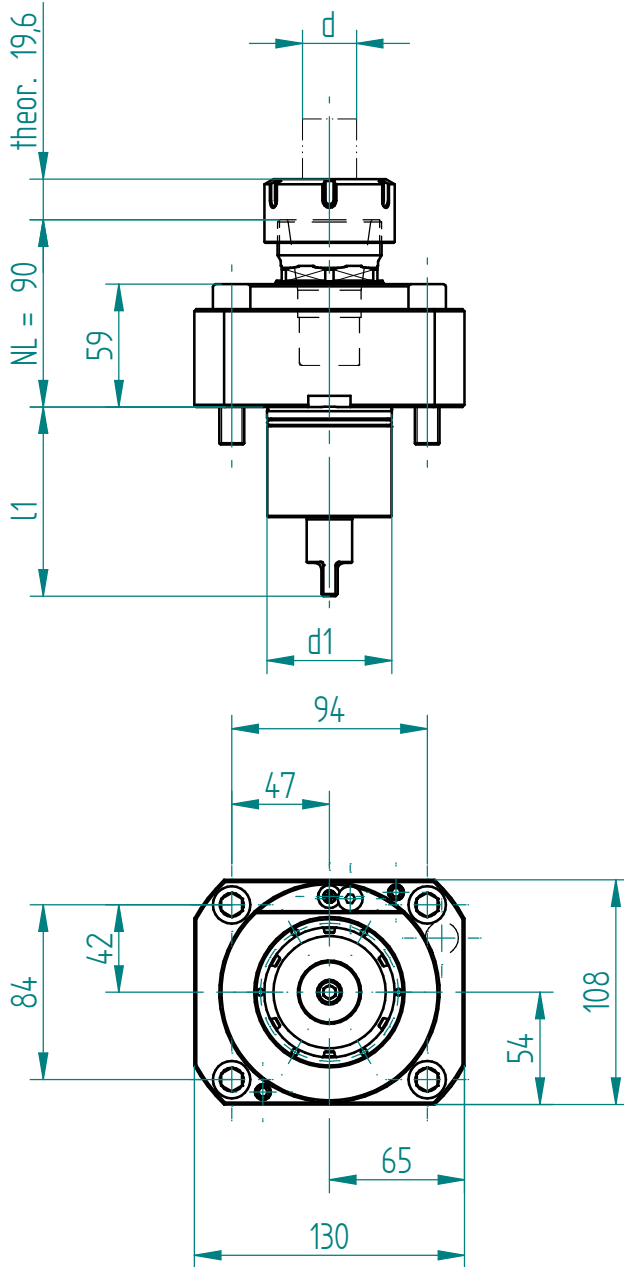

Änderungen vorbehalten. Subject to modification

Schnittstelle Revolver <i>interface tool turret</i>		Drehmoment <i>torque</i>	Drehzahl <i>tool speed</i>	Leistung <i>output</i>	Übersetzung <i>gear ratio</i>	Wkzg.Aufnahme Spannbereich <i>tool holding fixture clamping range</i>	Ausführung <i>version</i>	Bestell-Nr. <i>order N°</i>	
Schaft <i>shank</i>	Kupplung <i>coupling</i>								
d1 mm	l1 mm	M2 max Nm	n2 max 1/min	P max KW	i = n1 : n2	Spannbereich d <i>chucking capacity d</i>			
60	91.0	Mori Seiki	100.0	6000	5.5	1.00	ISO 15488 - 40 - A 3-26	gerade <i>straight</i>	<b>126790</b>

Erforderliche(r) Schlüssel zur Werkzeugspannung / *necessary key(s) for tool clamping*

133507

