

int. 5-80 bar
ext. 80 bar
- \diamond 50µm
- Dry run: max. 10%

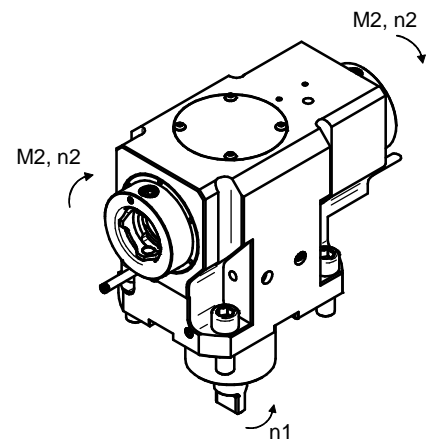
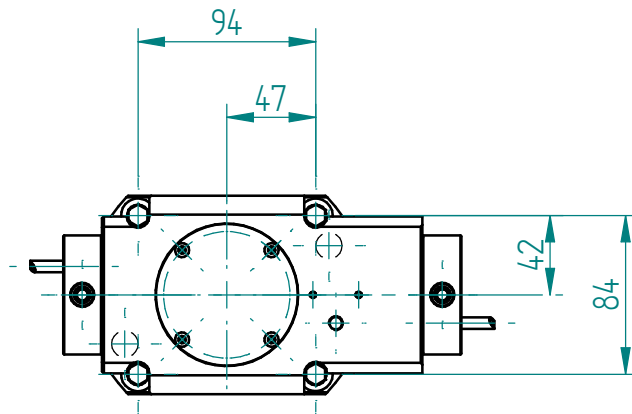
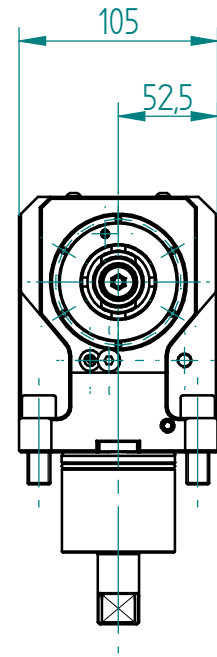
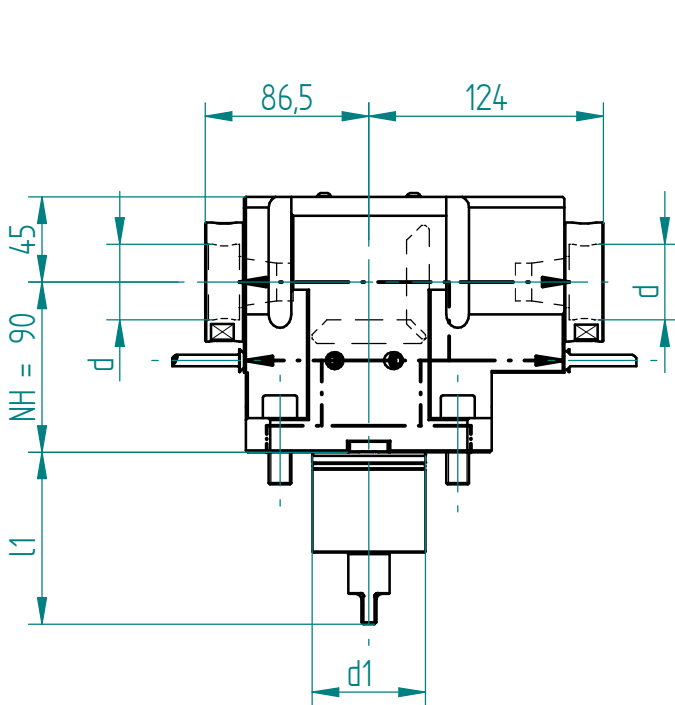

Änderungen vorbehalten. Subject to modification

Schnittstelle Revolver <i>interface tool turret</i>		Drehmoment <i>torque</i>	Drehzahl <i>tool speed</i>	Leistung <i>output</i>	Übersetzung <i>gear ratio</i>	Wkzg.Aufnahme Spannbereich <i>tool holding fixture clamping range</i>	Ausführung <i>version</i>	Bestell-Nr. <i>order N°</i>	
Schaft <i>shank</i>	Kupplung <i>coupling</i>								
d1 mm	l1 mm	M2 max Nm	n2 max 1/min	P max KW	i = n1: n2	Spannbereich d <i>chucking capacity d</i>			
60	91.0	BMT Mori Seiki 60	100.0	10000	5.5	1.00	Solidfix S4	universal universal	156411

Erforderliche(r) Schlüssel zur Werkzeugspannung / *necessary key(s) for tool clamping*

Inbusschlüssel / *Allen head wrench*

