

ext. 80 bar

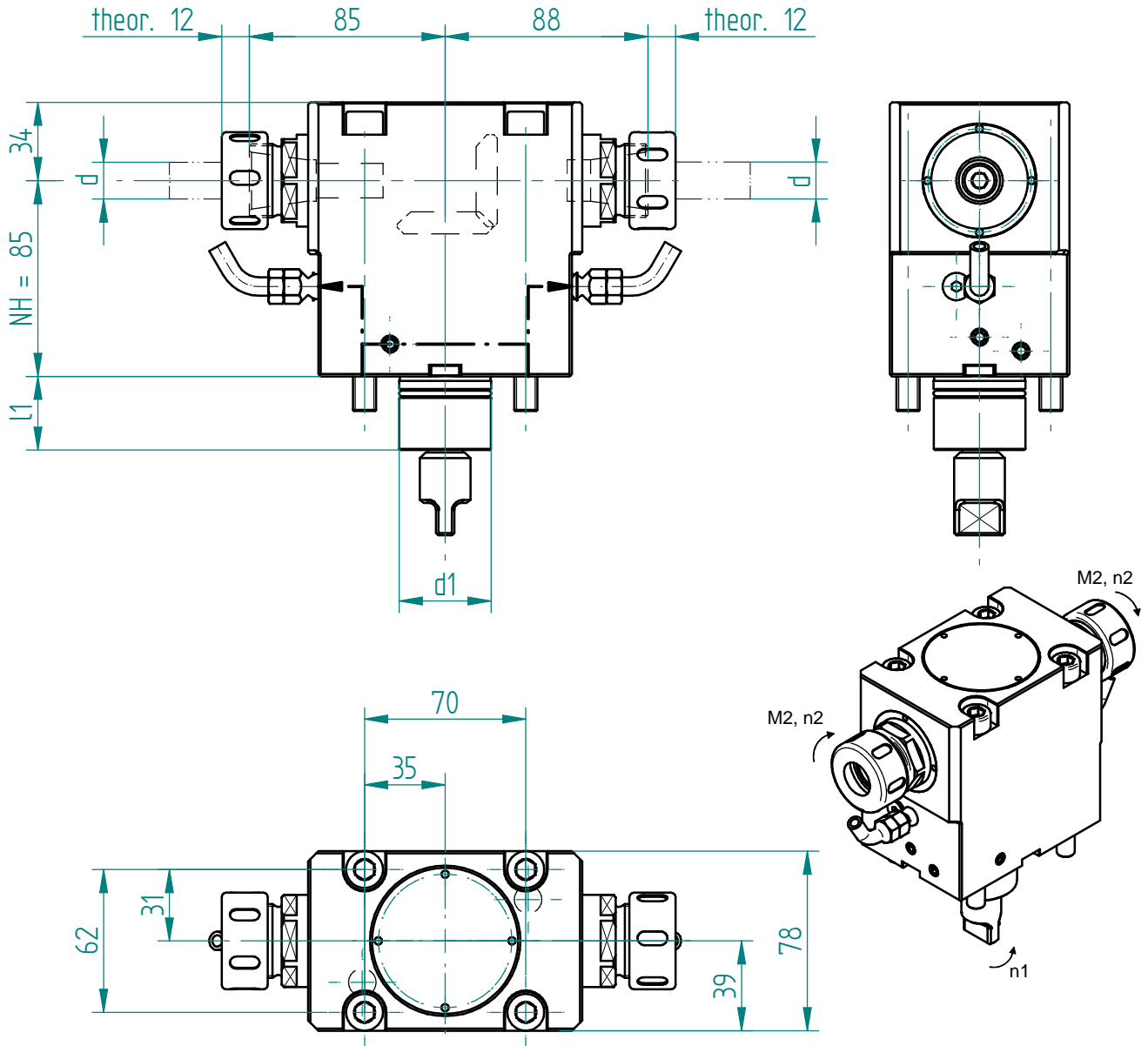

Änderungen vorbehalten. Subject to modification

Schaft shank		Drehmoment torque	Drehzahl tool speed	Leistung output	Übersetzung gear ratio	Wkzg.Aufnahme Spannbereich tool holding fixture clamping range	Kupplung coupling	Ausführung version	Bestell-Nr. order N°
d1 mm	l1 mm	M2 max Nm	n2 max 1/min	P max KW	i = n1: n2	Spannbereich d chucking capacity d			
40	32	32.0	6000	7.5	-1.00	DIN 6499 - 25 - A 1-16	Mori Seiki	universal universal	126308

Erforderliche(r) Schlüssel zur Werkzeugspannung / necessary key(s) for tool clamping

129817