

int. 5-80 bar
ext. 80 bar
- \diamond 50 μ m
- Dry run: max. 10%

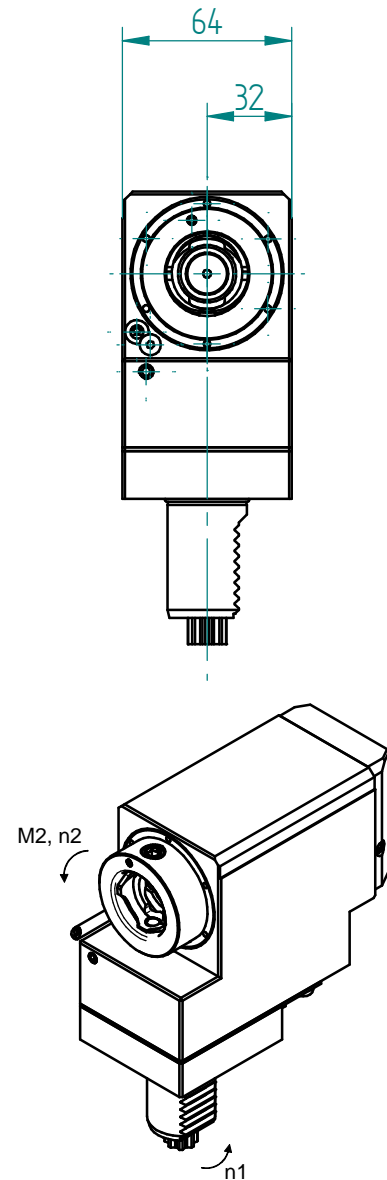
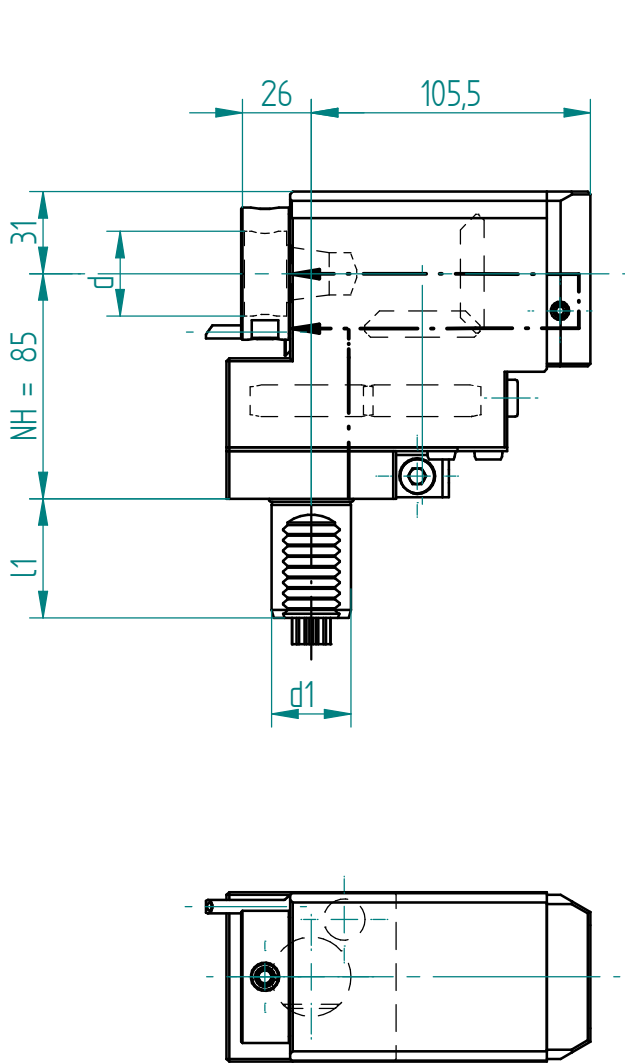

*nicht nach ISO 10889
*not according to ISO 10889

Änderungen vorbehalten. Subject to modification

Schnittstelle Revolver interface tool turret		Kupplung coupling	Drehmoment torque	Drehzahl tool speed	Leistung output	Übersetzung gear ratio	Wkzg.Aufnahme Spannbereich tool holding fixture clamping range	Ausführung version	Bestell-Nr. order N°
Schaft shank	ISO 10889								
d1 mm	l1* mm		M2 max Nm	n2 max 1/min	P max KW	i = n1: n2	Spannbereich d chucking capacity d		
30	45	DIN 5482 B 15x12	32.0	7000	8.0	1.00	Solidfix S3	rechts right	138369

Erforderliche(r) Schlüssel zur Werkzeugspannung / necessary key(s) for tool clamping

Inbusschlüssel / Allen head wrench