

Typenblatt  
Data Sheet

# Angetriebene Werkzeuge einstb. Spannzangeaufnahme

*adjustable driven tools ; collet chuck*

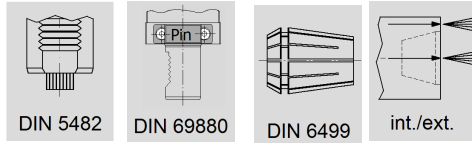

int. 25 bar  
ext. 80 bar  
- 50µm  
- Dry run: max. 10%

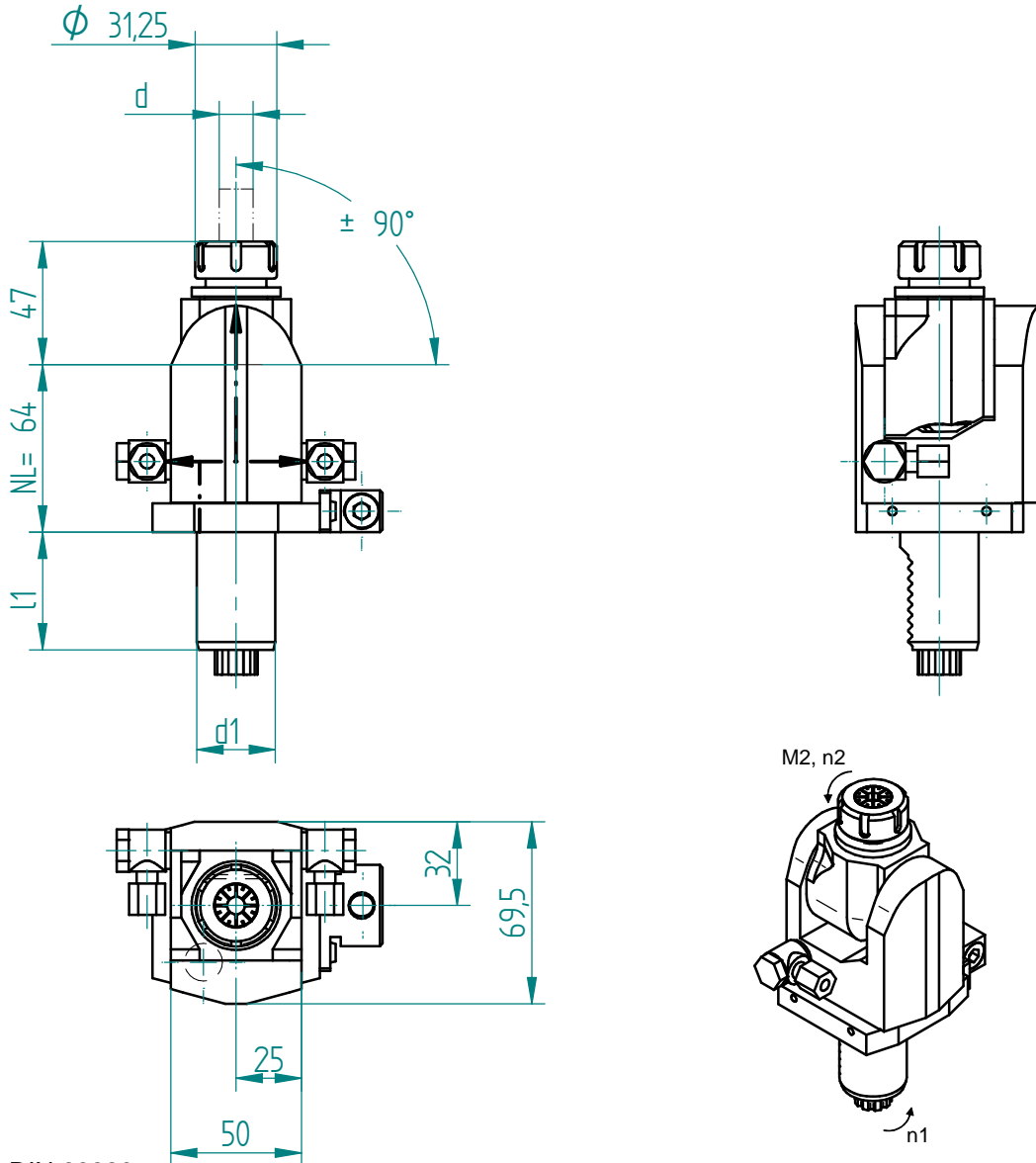

\*nicht nach DIN 69880  
\*not according to DIN 69880

Änderungen vorbehalten. Subject to modification

Schaft shank		Drehmoment torque	Drehzahl tool speed	Leistung output	Übersetzung gear ratio	Wkzg.Aufnahme Spannbereich tool holding fixture clamping range	Kupplung coupling	Ausführung version	Bestell-Nr. order N°
DIN 69880									
d1 mm	l1* mm	M2 max Nm	n2 max 1/min	P max KW	$i = n_1 : n_2$	Spannbereich d chucking capacity d			
30	45	15.0	6000	3.0	1.00	DIN 6499 - 20 - A 1-13	DIN 5482 B 15x12	links left	<b>132611</b>