

ext. 80 bar

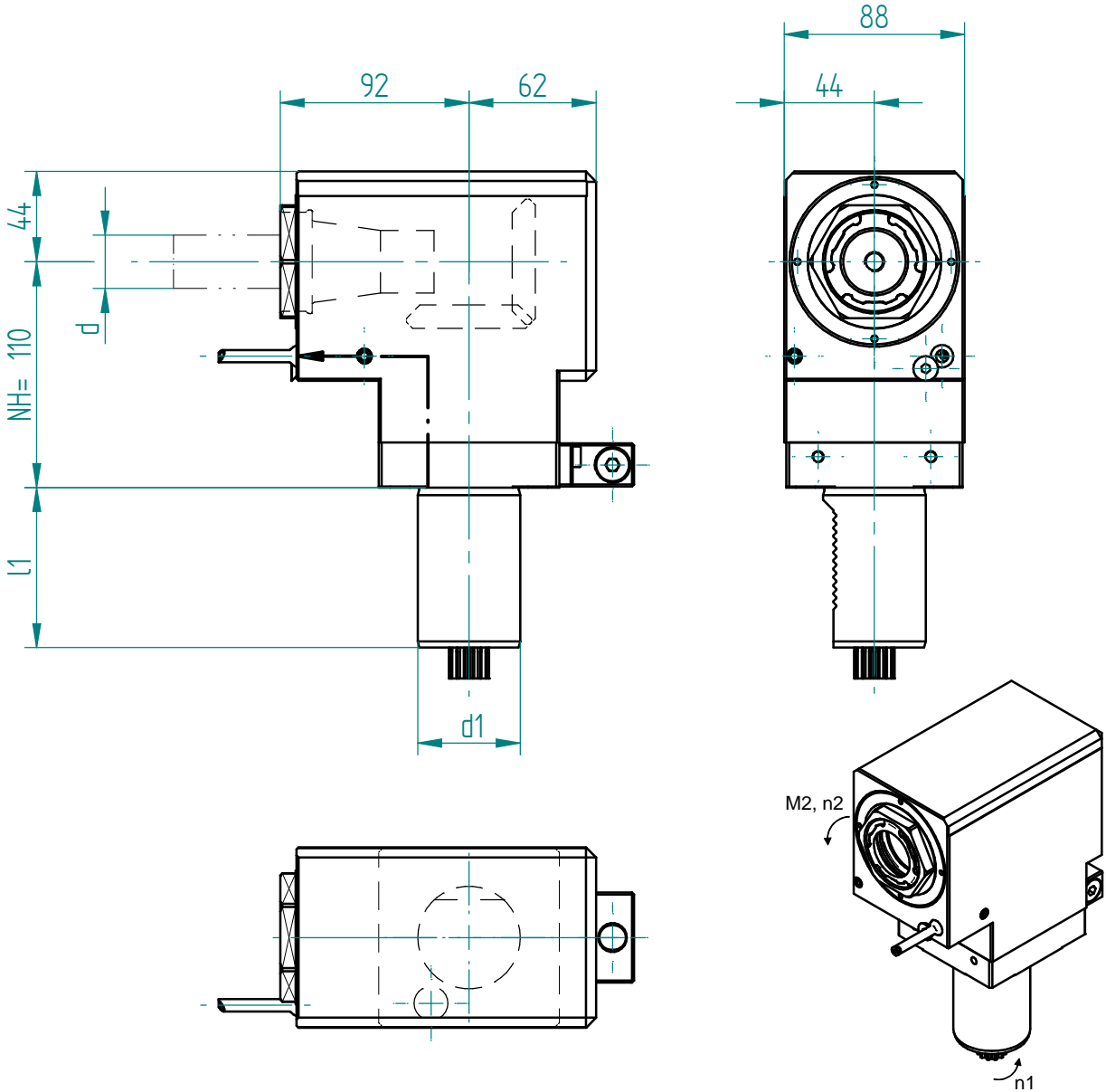

Änderungen vorbehalten. Subject to modification

Schnittstelle Revolver <i>interface tool turret</i>		Kupplung <i>coupling</i>	Drehmoment <i>torque</i>	Drehzahl <i>tool speed</i>	Leistung <i>output</i>	Übersetzung <i>gear ratio</i>	Wkzg.Aufnahme Spannbereich <i>tool holding fixture clamping range</i>	Ausführung <i>version</i>	Bestell-Nr. <i>order N°</i>
Schaft <i>shank</i>	ISO 10889								
d1 mm	l1 mm		M2 max Nm	n2 max 1/min	P max KW	i = n1 : n2	Spannbereich d <i>chucking capacity d</i>		
50	78	DIN 5482 B 20x17	100.0	4000	12.0	-1.00	ISO 15488 - 40 - I 3-26	links <i>left</i>	106607

Erforderliche(r) Schlüssel zur Werkzeugspannung / *necessary key(s) for tool clamping* 106113

Rev 12/2014 // Erst.: tba , erstellt am 2012.09.11 // Prüf.: has , geprüft am 2012.11.06