

ext. 80 bar

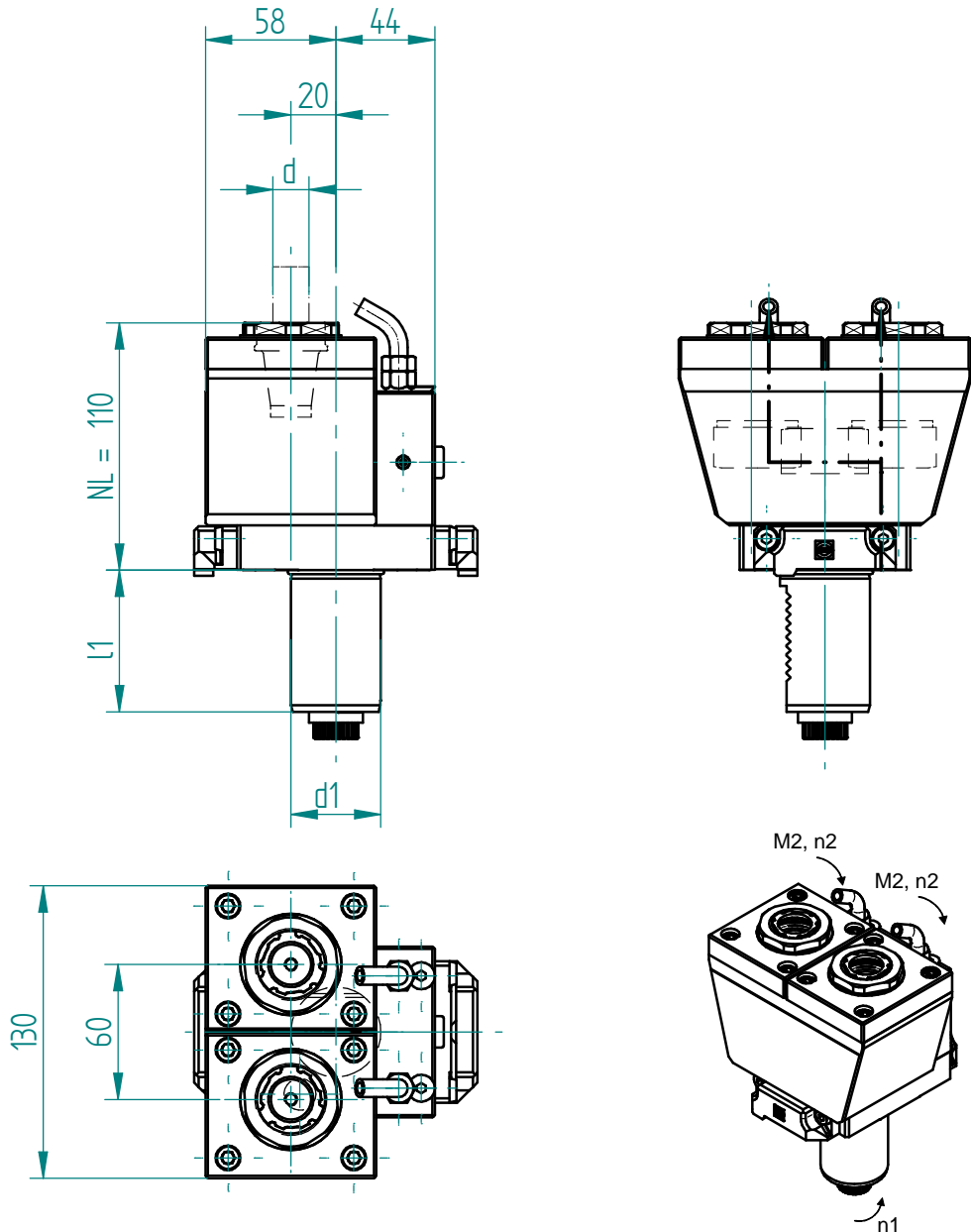

Änderungen vorbehalten. Subject to modification

Schaft shank		Drehmoment torque	Drehzahl tool speed	Leistung output	Übersetzung gear ratio	Wkzg.Aufnahme Spannbereich tool holding fixture clamping range	Kupplung coupling	Ausführung version	Bestell-Nr. order N°
DIN 69880									
d1 mm	l1 mm	M2 max Nm	n2 max 1/min	P max KW	$i = n_1 : n_2$	Spannbereich d chucking capacity d			
40	63	30.0	6000	18.8	-1.00	DIN 6499 - 25 - I 1-16	DIN 5480 W 20x0.8 x30x24	links left	142773

Erforderliche(r) Schlüssel zur Werkzeugspannung / necessary key(s) for tool clamping

105762