

Nowość / New

## Oprawki ER do gwintowania do gwintowania z synchronizacją

Tapping chucks for synchronized tapping

Gewindebohrfutter zum synchronen Gewindebohren

Резьбонарезные патроны ER с синхронизацией



**ER**  
DIN6499

**SYNCHRONIZED**

**TAPPING**

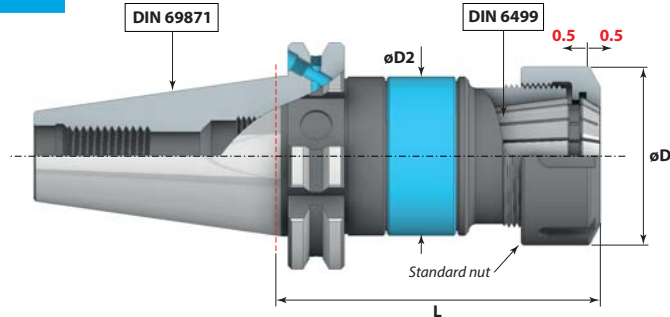

**DIN 69871 (DIN)** | **MAS 403-BT (BT)**

Kod produktu Order No. / Bestell-Nr. / Код товара		Stożek Holder (7-24)	Tulejka Collet (DIN6499)	Zakres gwint. Tapping range (mm)	ø D (mm)	L DIN / BT (mm)	ø D2 (mm)
DIN40.ER16SY.L79	BT40.ER16SY.L79	40	ER16	M3 ÷ M12	32	79/79	34
DIN40.ER25SY.L84	BT40.ER25SY.L89	40	ER25	M3 ÷ M20	42	84/89	45
DIN40.ER32SY.L95	BT50.ER32SY.L110	40	ER32	M3 ÷ M27	50	95/110	45
DIN40.ER40SY.L120	BT50.ER40SY.L115	40	ER40	M5 ÷ M33	63	120/115	62

AD+B

### Produkty powiązane / Related Products



## Oprawki zaciskowe typu STRONG

STRONG milling chuck

STRONG Fräsfutter

Цанговые патроны STRONG



**STRONG**

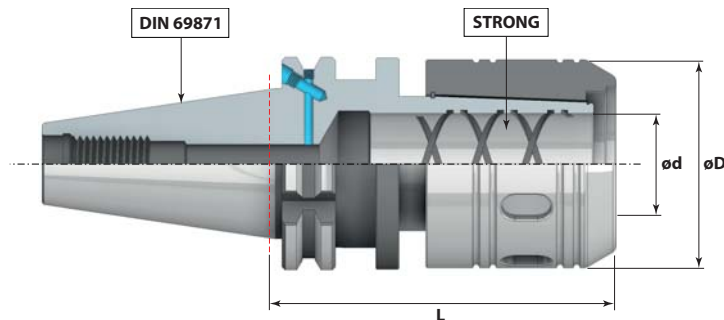

**DIN 69871 (DIN)** | **MAS 403-BT (BT)**

Kod produktu Order No. / Bestell-Nr. / Код товара		Stożek Holder (7-24)	ø d (mm)	L DIN / BT (mm)	ø D (mm)
DIN40.ST20.L75	BT40.ST20.L80	40	20	75/80	46
DIN40.ST32.L95	BT40.ST32.L85	40	32	95/85	62
DIN50.ST20.L85	BT50.ST20.L100	50	20	85/100	46
DIN50.ST32.L85	BT50.ST32.L100	50	32	85/100	62

**G6,3**  
12 000 r.p.m.  
STANDARD  
**AD+B**

### Produkty powiązane / Related Products



Uchwyty narzędziowe / Toolholders

1  
2  
3  
4  
5  
6  
7  
8  
9  
10  
11  
12  
13  
14  
15