

UCHWYTY CYLINDRYCZNE / CYLINDRICAL CHUCKS

Nowość / New

Oprawki ER do gwintowania z kompensacją osiową

Tension and compression ER collet tap holders

Spannzangenhalter für Zug und Druck ER

Резьбонарезные патроны с цилиндрическим хвостовиком



ER DIN6499	TANSION & COMPRESSION	TAPPING
----------------------	----------------------------------	----------------

Kod produktu Order No. Bestell-Nr. Код товара	ø d (mm)	ø D (mm)	L (mm)	L2 (mm)	Zakres gwintowania Tapping range	C (mm)	T (mm)
FI16.ER16TC.L32	16	29	32	48	M3 ÷ M12	2,5	5,5
FI20.ER16TC.L32	20	29	32	48	M3 ÷ M12	2,5	5,5
FI20.ER25TC.L46	20	44	46	73	M3 ÷ M20	3	9
FI25.ER25TC.L50	25	58	50	68	M3 ÷ M20	4	12
FI25.ER25TC.L80	25	58	80	68	M3 ÷ M20	4	12
FI32.ER25TC.L50	32	58	50	68	M3 ÷ M20	4	12
FI40.ER25TC.L85	40	58	85	68	M3 ÷ M20	4	12
FI25.ER32TC.L50	25	58	50	70	M3 ÷ M27	4	12
FI25.ER32TC.L80	25	58	80	70	M3 ÷ M27	4	12
FI32.ER32TC.L50	32	58	50	70	M3 ÷ M27	4	12
FI40.ER32TC.L85	40	58	85	70	M3 ÷ M27	4	12

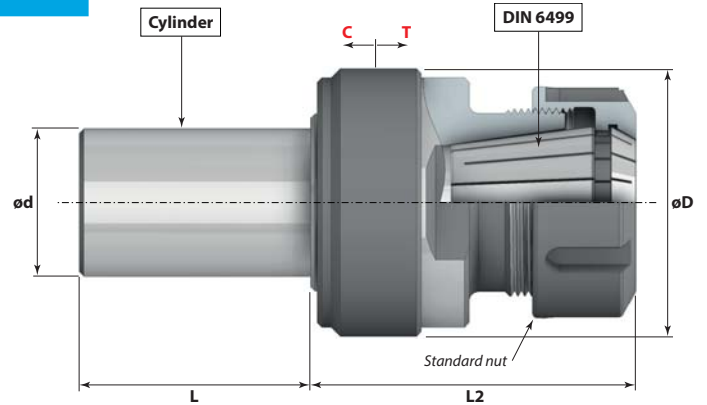

Produkty powiązane / Related Products



Nowość / New

Oprawki ER do gwintowania z kompensacją osiową

Tension only ER collet tap holders

Nur ER-Spannzangenhalter spannen

Резьбонарезные патроны с цилиндрическим хвостовиком



ER DIN6499	TANSION ONLY	TAPPING
----------------------	---------------------	----------------

Kod produktu Order No. Bestell-Nr. Код товара	ø d (mm)	ø D (mm)	L (mm)	L2 (mm)	Zakres gwintowania Tapping range	T (mm)
FI16.ER16T.L32	16	29	32	48	M3 ÷ M12	8
FI20.ER16T.L32	20	29	32	48	M3 ÷ M12	8
FI20.ER25T.L46	20	44	46	70	M3 ÷ M20	12
FI25.ER25T.L50	25	58	50	64	M3 ÷ M20	16
FI25.ER25T.L80	25	58	80	64	M3 ÷ M20	16
FI32.ER25T.L50	32	58	50	64	M3 ÷ M20	16
FI40.ER25T.L85	40	58	85	64	M3 ÷ M20	16
FI25.ER32T.L50	25	58	50	66	M3 ÷ M27	16
FI25.ER32T.L80	25	58	80	66	M3 ÷ M27	16
FI32.ER32T.L50	32	58	50	64	M3 ÷ M27	16
FI40.ER32T.L85	40	58	85	64	M3 ÷ M27	16

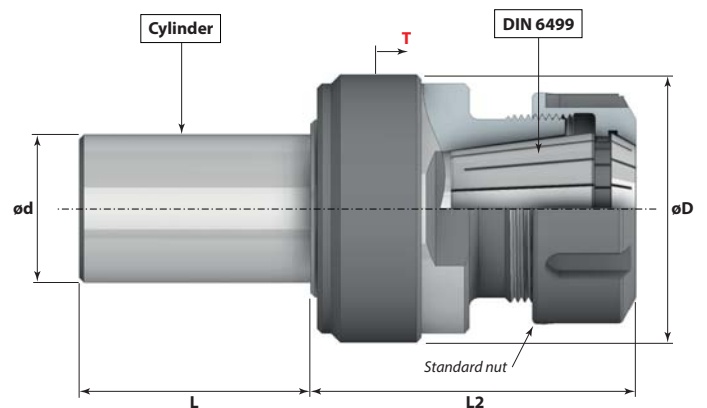

Produkty powiązane / Related Products

