

## Oprawki zaciskowe do tulejek ER (MINI)

Collet chucks for collets DIN6499 (ER MINI)  
Spannfutter für Spannzangen DIN6499 (ER MINI)  
Патроны цанговые ER по DIN 6499 (МИНИ)



**ER**  
DIN6499

**MINI**

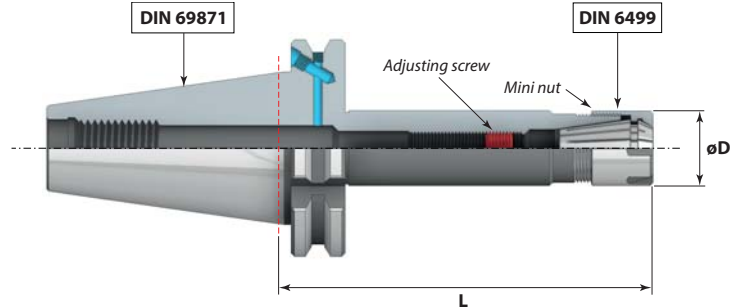

**DIN 69871 (DIN)**

**MAS 403-BT (BT)**

Kod produktu Order No. / Bestell-Nr. / Код товара		Stożek Holder (7-24)	Tulejka Collet (DIN6499)	L (mm)	Zakres moc. Clamp. Range (mm)	ø D (mm)
DIN40.ER11M.L70		40	ER11	70	1 ÷ 8	16
DIN40.ER11M.L100	BT40.ER11M.L100	40	ER11	100	1 ÷ 8	16
	BT40.ER11M.L160	40	ER11	160	1 ÷ 8	16
DIN40.ER16M.L70		40	ER16	70	1 ÷ 12	22
DIN40.ER16M.L100	BT40.ER16M.L100	40	ER16	100	1 ÷ 12	22
DIN40.ER16M.L160	BT40.ER16M.L160	40	ER16	160	1 ÷ 12	22
DIN40.ER20M.L100	BT40.ER20M.L100	40	ER20	100	1 ÷ 16	28
DIN40.ER20M.L160	BT40.ER20M.L160	40	ER20	160	1 ÷ 16	28
DIN40.ER25M.L100	BT40.ER25M.L100	40	ER25	100	1 ÷ 20	35
DIN40.ER25M.L160	BT40.ER25M.L160	40	ER25	160	1 ÷ 20	35
DIN50.ER16M.L100	BT50.ER16M.L100	50	ER16	100	1 ÷ 12	22
DIN50.ER16M.L160	BT50.ER16M.L160	50	ER16	160	1 ÷ 12	22
DIN50.ER20M.L100	BT50.ER20M.L100	50	ER20	100	1 ÷ 16	28
DIN50.ER20M.L160	BT50.ER20M.L160	50	ER20	160	1 ÷ 16	28
DIN50.ER25M.L100	BT50.ER25M.L100	50	ER25	100	1 ÷ 20	35
DIN50.ER25M.L160	BT50.ER25M.L160	50	ER25	160	1 ÷ 20	35

**G6,3**

12 000 r.p.m.  
STANDARD

**AD+B**

**G2,5**

25 000 r.p.m.  
OPTION

### DOUBLE CONTACT (DC):

**Nowość / New**

DIN40DC.ER11M.L100	BT40DC.ER11M.L100	40	ER11	100	1 ÷ 8	16
DIN40DC.ER16M.L100	BT40DC.ER16M.L100	40	ER16	100	1 ÷ 12	22
DIN40DC.ER20M.L100	BT40DC.ER20M.L100	40	ER20	100	1 ÷ 16	28
DIN50DC.ER11M.L100	BT50DC.ER11M.L100	50	ER11	100	1 ÷ 8	16
DIN50DC.ER16M.L100	BT50DC.ER16M.L100	50	ER16	100	1 ÷ 12	22
DIN50DC.ER20M.L100	BT50DC.ER20M.L100	50	ER20	100	1 ÷ 16	28

**G2,5**

25 000 r.p.m.  
STANDARD

**AD+B**

### Produkty powiązane / Related Products



Uchwyty narzędziowe wymienione w tabeli są standardem. Wykonujemy również uchwyty w wersji specjalnej wg ustaleń klienta.  
Toolholders in the table are the standard. We also make toolholders in the special version according to the customer settlements.