

## Tuleje redukcyjne do narzędzi z chwytem Morse'a z płetwą wg DIN228-B

Morse taper adaptor DIN228-B

Zwischenhülsen für MK mit Austreiblappen DIN228-B

Переходные втулки для инструмента с конусом Морзе с лапкой по DIN 228-B



### MORSE

Kod produktu Order No. Bestell-Nr. Код товара	ø D (mm)	Stożek Taper (Morse)	L (mm)
FI25.MK1.L89	25	MK1	89
FI25.MK2.L89	25	MK2	89
FI32.MK1.L100	32	MK1	100
FI32.MK2.L100	32	MK2	100
FI32.MK3.L120	32	MK3	120
FI40.MK2.L100	40	MK2	100
FI40.MK3.L120	40	MK3	120
FI40.MK4.L152	40	MK4	152

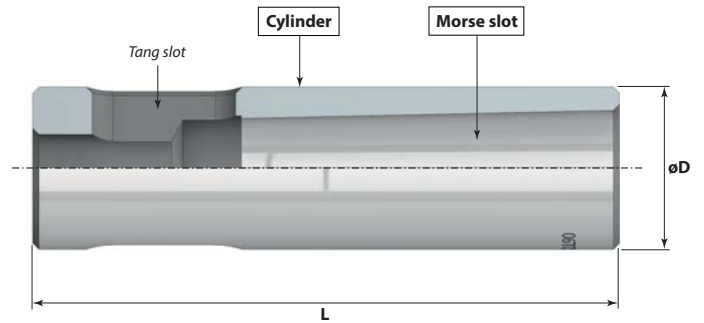

#### Produkty powiązane / Related Products



### Nowość / New

## Oprawki pływające do rozwiertaków z przepływem chłodziwa

Floating reamer holders with coolant through

Pendelhalter mit Innenkühlung

Плавающие патроны для развёрток с подводом СОЖ



ER  
DIN6499

FOR REAMERS

Kod produktu Order No. Bestell-Nr. Код товара	ø d (mm)	ø D (mm)	L (mm)	L2 (mm)	Zakres mocowania Clamping range (mm)
FI16.ER16RM.L46	16	42	46	44	1 ÷ 10
FI20.ER16RM.L46	20	42	46	44	1 ÷ 10
FI25.ER16RM.L46	25	42	46	44	1 ÷ 10
FI16.ER25RM.L46	16	57	46	53	1 ÷ 20
FI20.ER25RM.L46	20	57	46	53	1 ÷ 20
FI25.ER25RM.L46	25	57	46	53	1 ÷ 20
FI32.ER25RM.L46	32	57	46	53	1 ÷ 20
FI25.ER32RM.L50	25	57	50	53	2 ÷ 22
FI32.ER32RM.L50	32	57	50	53	2 ÷ 22
FI25.ER40RM.L50	25	79	50	64	3 ÷ 30
FI32.ER40RM.L50	32	79	50	64	3 ÷ 30

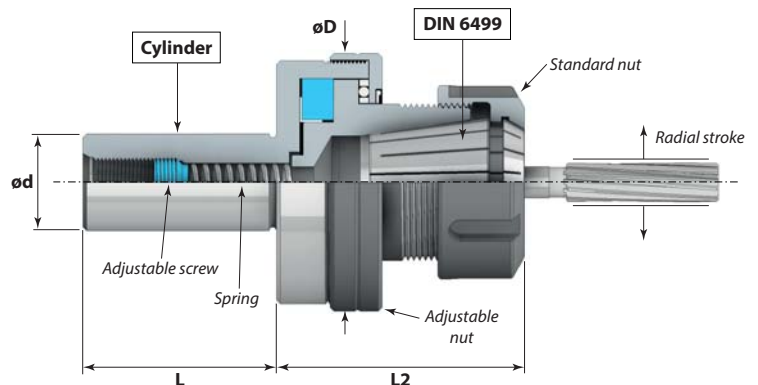

#### Produkty powiązane / Related Products

