

int. 5-80 bar
ext. 80 bar
- \diamond 50 μ m
- Dry run: 100%

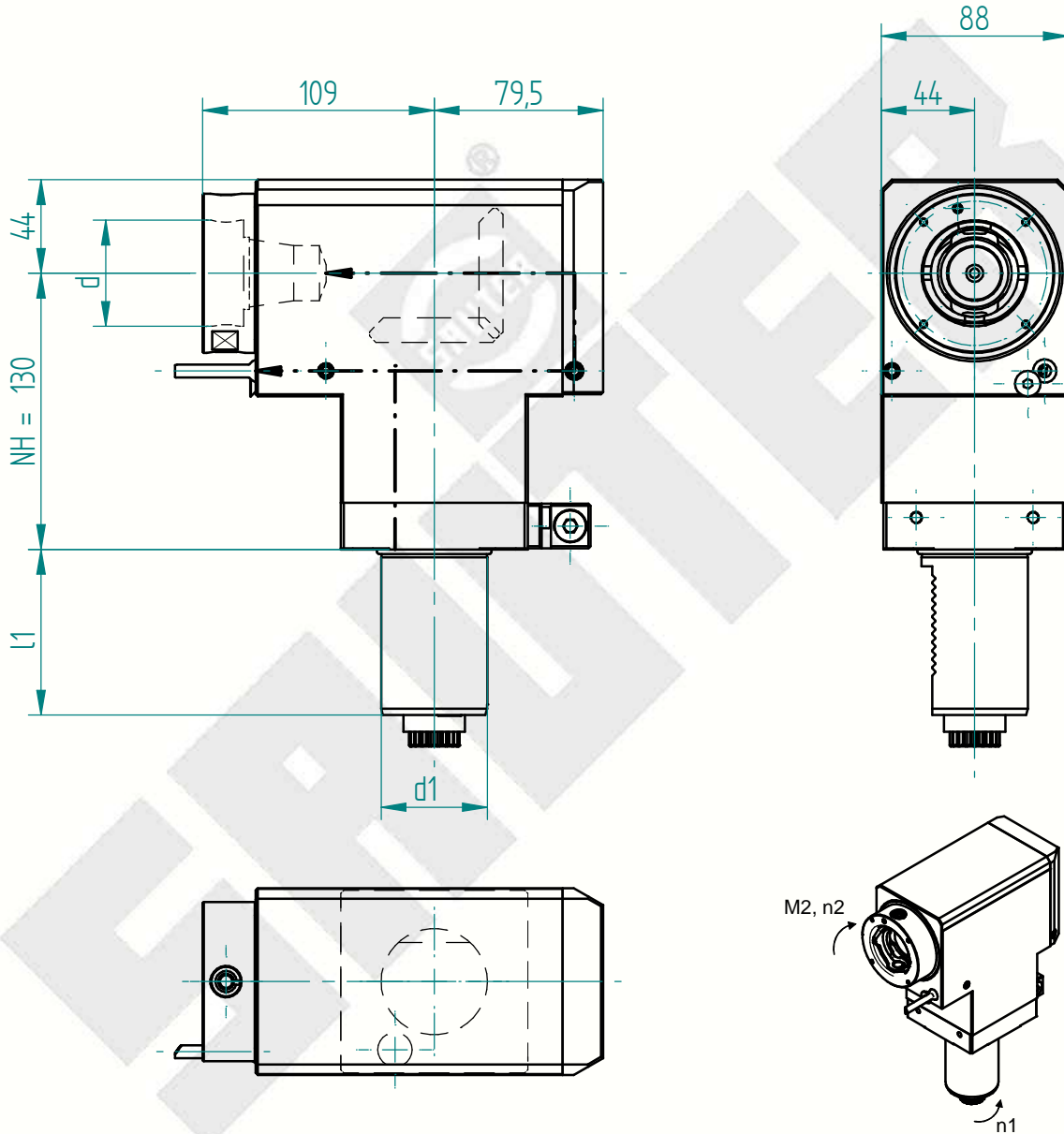

Schnittstelle Revolver <i>interface tool turret</i>		Kupplung <i>coupling</i>	Drehmoment <i>torque</i>	Drehzahl <i>tool speed</i>	Leistung <i>output</i>	Übersetzung <i>gear ratio</i>	Wkzg.Aufnahme Spannbereich <i>tool holding fixture clamping range</i>	Ausführung <i>version</i>	Bestell-Nr. <i>order N°</i>
Schaft / BG <i>shank / size</i>									
d1 mm	l1 mm		M2 max Nm	n2 max 1/min	P max KW	i = n1: n2	Spannbereich d <i>chucking capacity d</i>		
50	78.0	DIN 5480 W 24x1.25x30x18	100.0	5000	12.0	1.000	Solidfix S5	links <i>left</i>	149756

Erforderliche(r) Schlüssel zur Werkzeugspannung / *necessary key(s) for tool clamping*
(nicht im Lieferumfang enthalten / *not included in delivery*)

Inbusschlüssel / *Allen head wrench*

