

int. 80 bar  
ext. 80 bar

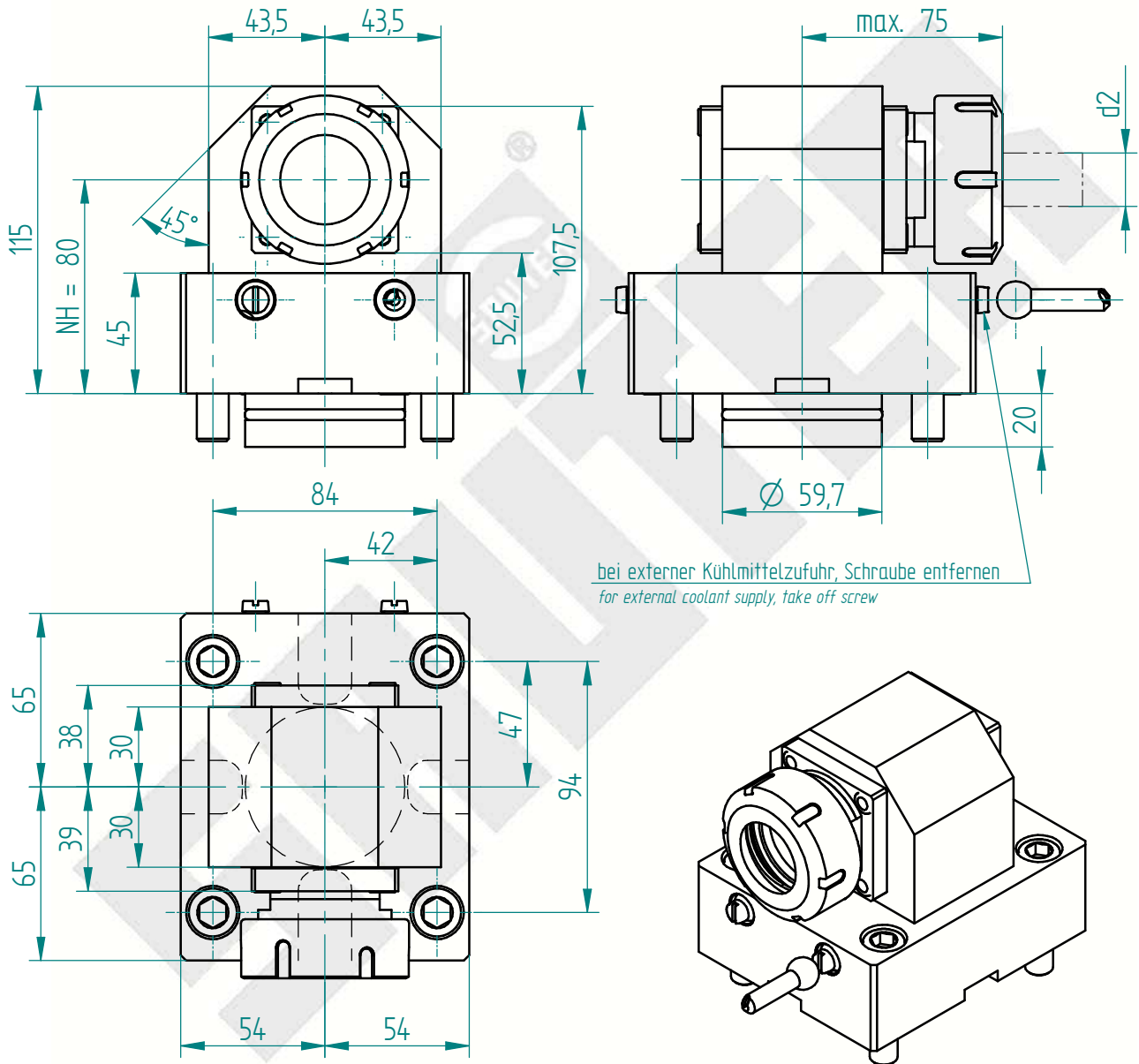

Schnittstelle Revolver interface tool turret	Werkzeugaufnahme tool location	Ausführung version	Bestell-Nr. order N°
BMT Mori Seiki 60	Aufnahme d2 location d2 ISO 15488 - 40 - A	universal universal	173390

Erforderliche(r) Schlüssel zur Werkzeugspannung / necessary key(s) for tool clamping  
(nicht im Lieferumfang enthalten / not included in delivery)

Inbusschlüssel / Allen head wrench

