

int. 5-80 bar  
ext. 80 bar  
-  $\diamond$  50 $\mu$ m  
- Dry run: max. 10%

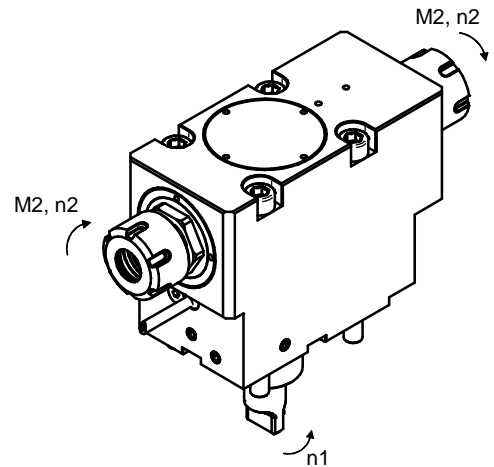
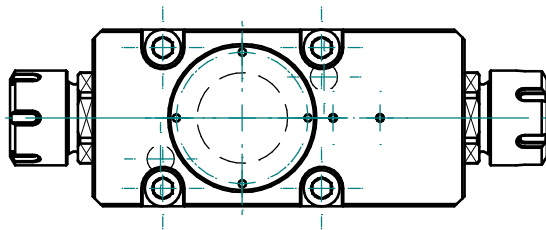
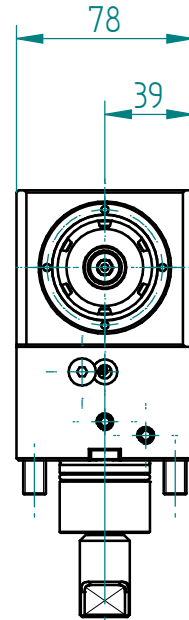
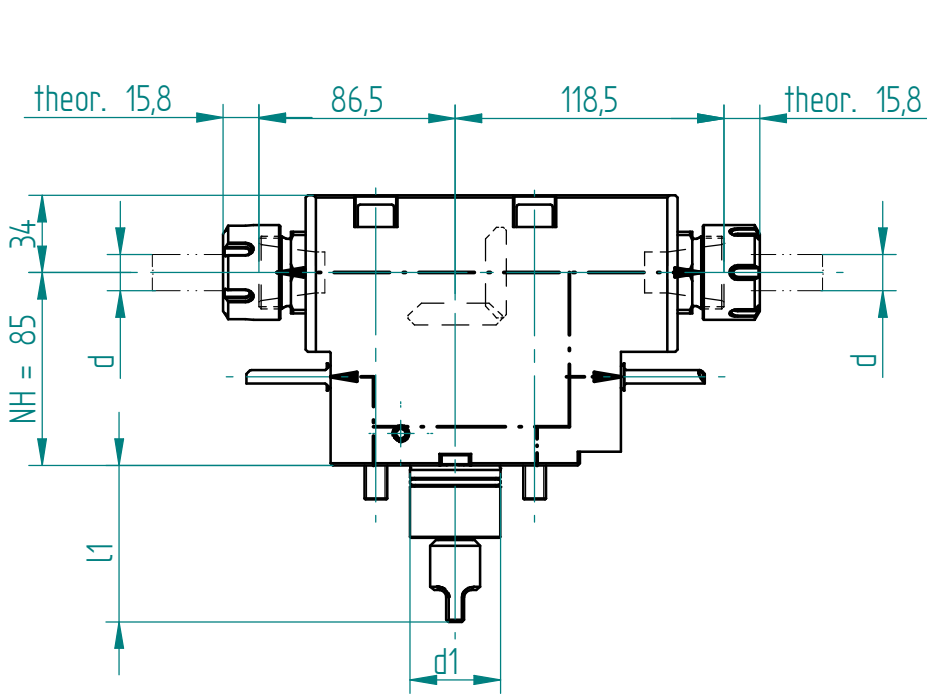

Schnittstelle Revolver <i>interface tool turret</i>		Drehmoment <i>torque</i>	Drehzahl <i>tool speed</i>	Leistung <i>output</i>	Übersetzung <i>gear ratio</i>	Wkzg.Aufnahme Spannbereich <i>tool holding fixture clamping range</i>	Ausführung <i>version</i>	Bestell-Nr. <i>order N°</i>
Schaft <i>shank</i>	Kupplung <i>coupling</i>							
d1 mm	l1 mm	M2 max Nm	n2 max 1/min	P max KW	i = n1 : n2	Spannbereich d <i>chucking capacity d</i>		
40	69.0	BMT Mori Seiki 40 32.0	12000	7.5	1.00	ISO 15488 - 25 - A 1-16	universal universal	149981

Erforderliche(r) Schlüssel zur Werkzeugspannung / *necessary key(s) for tool clamping*

147732

